

PRODUCT DATA DRAWING

REVISION HISTORY			
REV	DESCRIPTION	DATE	APPROVED
-	REV. DCN 39276	08/09/12	STW
A	REV. DCN 48229	01/04/19	STW

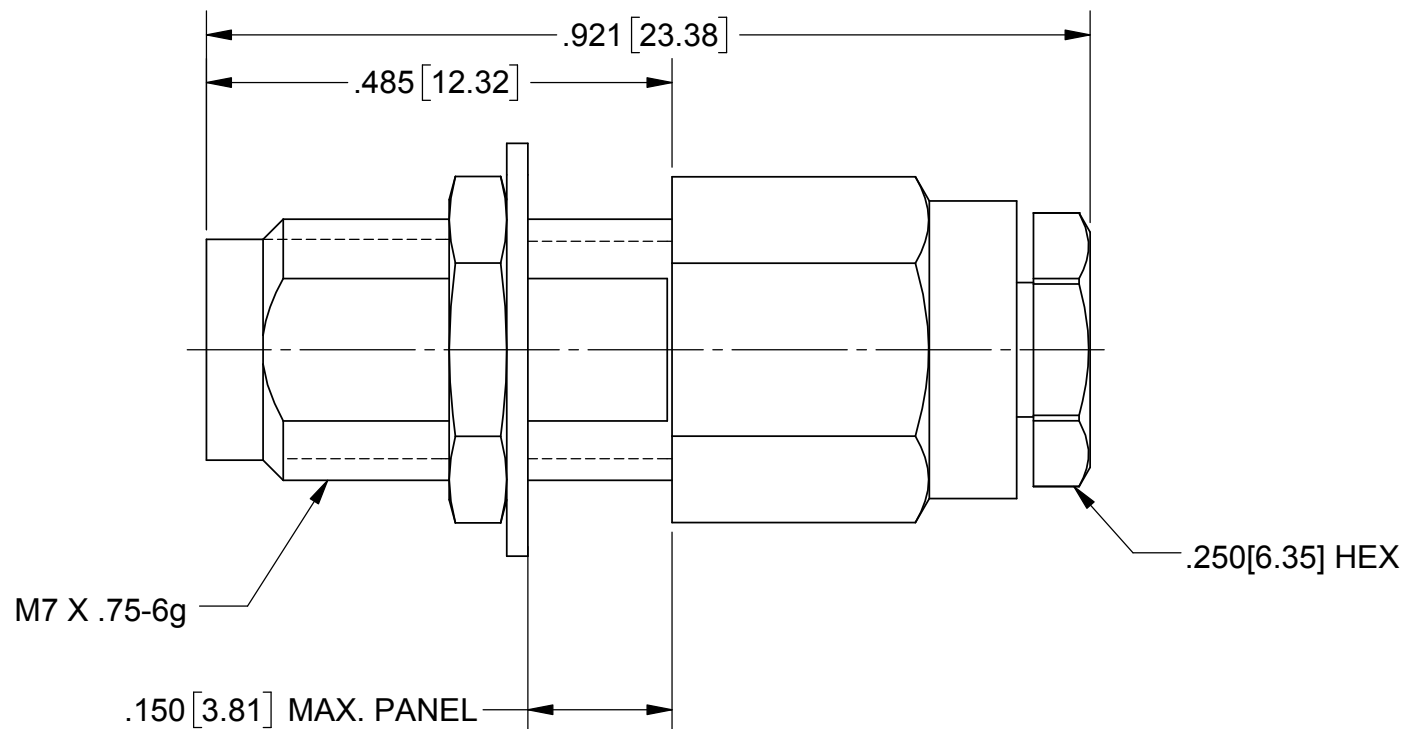
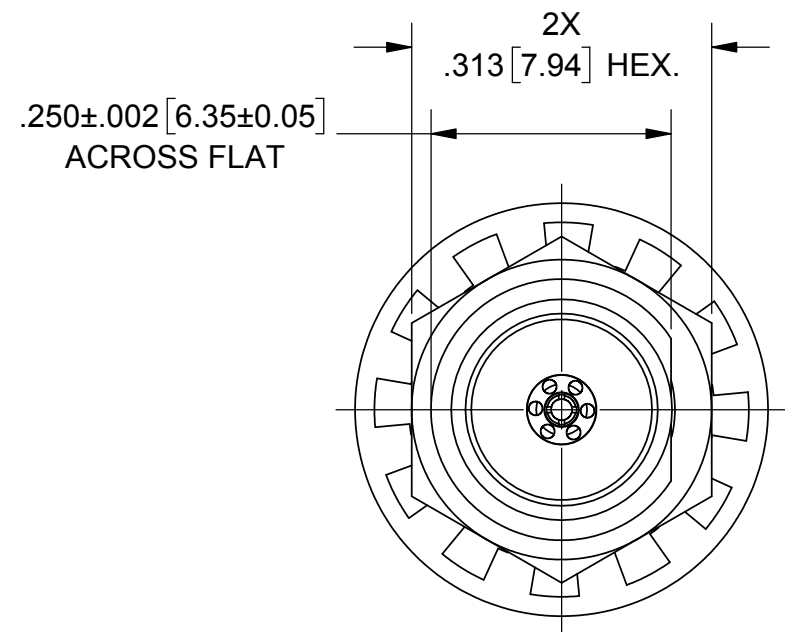

MATERIAL:

BODY, HEX NUT,
FERRULE, CLAMP NUT,
& INSERT:

STAINLESS STEEL PER AMS-5640, ALLOY UNS S30300, TYPE 1
OR ASTM A582, TYPE 303, CONDITION A.

CONTACT:

BERYLLIUM COPPER PER ASTM B196, ALLOY No. UNS C17300, TD04.

LOCKWASHER:

STAINLESS STEEL 300 SERIES

INSULATOR:

PCTFE PER ASTM D1430

FINISH:

BODY, HEX NUT,
CLAMP NUT & INSERT: PASSIVATED PER AMS 2700.

**FERRULE &
CONTACT:**

GOLD PER ASTM B488, TYPE II, CODE C, CLASS 1.27,
OVER NICKEL PER AMS-QQ-N-290, CLASS 1, .000050" MIN.

PERFORMANCE:

IMPEDANCE: 50 OHMS
FREQ. RANGE: DC TO 65.0 GHz
VSWR: 1.33:1 DC TO 65.0 GHz
INSERTION LOSS: .03 X SQRT(F(F IN GHz))
DWV: 500 VRMS
OPERATING TEMP.: -55 °C TO +125 °C

ENGAGEMENT/
DISENGAGEMENT: 2 IN-LBS

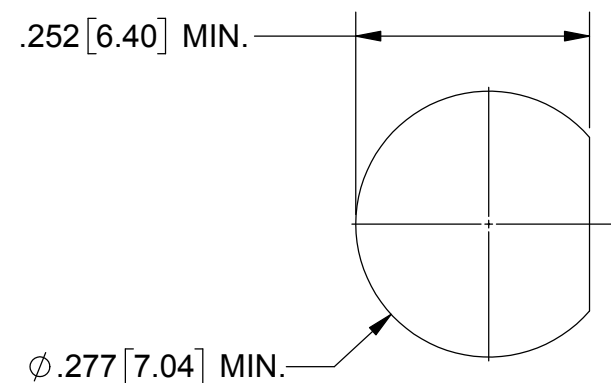

RECOMMENDED MOUNTING HOLE

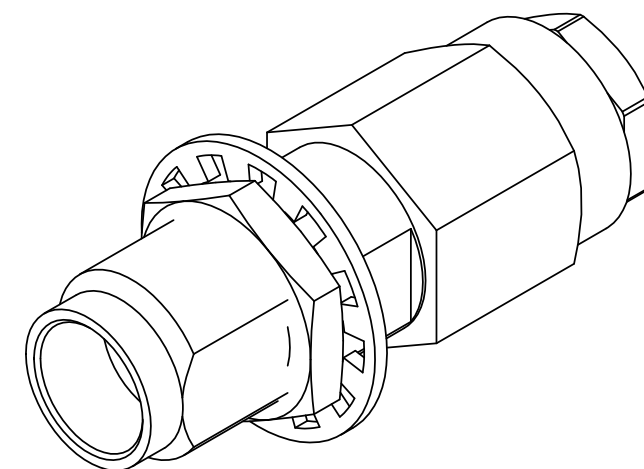

MATERIAL: SEE NOTES	DIMENSIONS ARE IN INCHES TOLERANCES: FRACTIONAL: ±1/64 ANGULAR: X° ±1'0" X'X' ±15'	UNLESS OTHERWISE SPECIFIED 1) ALL DIMENSIONS ARE IN INCHES (MILLIMETERS) 2) ALL DIMENSIONS ARE AFTER PLATING. 3) BREAK CORNERS & EDGES .005 R. MAX. 4) CHAM. 1ST & LAST THREADS. 5) SURFACE ROUGHNESS 63-MIL-STD-10. 6) DIA. 'S ON COMMON CENTERS TO BE CONCENTRIC WITHIN .005 T.I.R. 7) REMOVE ALL BURRS	SV Microwave, Inc. 2400 Centrepark West Drive, Suite 100 West Palm Beach, FL 33409
FINISH: SEE NOTES	DECIMAL: X ±.030 .XX ±.010 .XXX ±.005	INTERPRET DIMENSIONS AND TOLERANCES PER ASME Y14.5M - 1994	TITLE: 1.85MM JACK, BULKHEAD MT. FOR Ø.047 CABLE
SURFACE AREA: N/A	THIRD ANGLE PROJECTION	DRAWN: JMC 08/08/12	SIZE: B CAGE CODE: 95077 DWG. NO.: SF3321-60004
PROPRIETARY THE INFORMATION CONTAINED IN THIS DRAWING IS THE SOLE PROPERTY OF SV MICROWAVE, INC. ANY REPRODUCTION IN PART OR AS A WHOLE WITHOUT THE WRITTEN PERMISSION OF SV MICROWAVE, INC IS PROHIBITED.		CHECKED: STW 08/09/12	SCALE: 5:1
		APPROVED: STW 08/09/12	SHEET 1 OF 1